



CO₂ + Air Quality DETECTOR With Temperature and RH detection

Model: G01-IAQ series

- ◆ Real time detection and transmission of carbon dioxide and air quality (VOC's)
- ◆ High accuracy temperature and relative humidity detection
- ◆ Up to 3xanalog linear outputs for measurements
- ◆ Modbus RS485 interface
- ◆ Optional LCD display
- ◆ CE-approval

■ Features

- ◆ Designed for real time measuring ambience carbon dioxide level, air quality (VOC's), temperature and relative humidity.
- ◆ NDIR infrared CO₂ sensor inside with special Self Calibration. It makes CO₂ measurement more accurate and reliable.
- ◆ More than 10 years lifetime of CO₂ sensor.
- ◆ Mix gases sensor with high sensitivity for VOC and cigarette.
- ◆ High accuracy temperature and relative humidity measurement optional
- ◆ Combined both humidity and temperature sensors seamlessly with digital auto compensation
- ◆ Provide up to 2 or 3 analog outputs for CO₂, air quality (VOC's) and temperature or relative humidity.
- ◆ With LCD or without LCD selectable
- ◆ LCD display CO₂, temperature and humidity measurements as well as air quality (VOC's) level.
- ◆ Wall mounting type with easy installation.
- ◆ Modbus RS485 interface with outputs for CO₂, temperature, humidity and air quality (VOC's).
- ◆ 24VAC/VDC power supply
- ◆ EU standard

■ Detection Focus

✓ Carbon Dioxide (CO₂)

Indoor CO₂ level is a universal accepted parameter for the condition of indoor ventilation and air quality.

- Non-dispersive infrared (NDIR) CO₂ sensor with more than 10-year lifetime
- ABC self-calibration technology guarantees reliable CO₂ measurement
- CO₂ range: 0~2000ppm/0~5000ppm optional
- Rapid response, high stability and consistency



✓ Air Quality (VOC)

The air quality sensor is a mix gases sensor with high sensitivity for VOC (kinds of volatile pollutant gases) such as ammonia, toluene, formaldehyde and cigarette smoke, alcohol, H₂S, and carbon monoxide. So it is very suitable to detector the general indoor air quality in real time and long term. It responds quickly to any change of the concentration of such gases.

- Semi-conduct mix gases sensor with 5~7 years life time
- High sensitive to volatile gases like ammonia, toluene, formaldehyde, cigarette smoke, alcohol, H₂S, etc.
- Small volume, lower consumption

✓ Temperature and humidity

Combined digital temperature and humidity sensor with high accuracy and stability. It also has compensation to CO₂ and air quality which makes the measurements more accurate by minimizing environmental effects.

■ Application

- ◆ Building ventilation systems
- ◆ Industry ventilation systems
- ◆ Airport, train station, shopping mall, office, classroom and other public places for air quality measurement and indication

■ Specifications

Monitoring parameters	CO ₂	Air Quality (VOC's)	Temperature	Relative humidity
Sensing element	Non-Dispersive Infrared Detector (NDIR)	Semiconductor mix gases sensor	Digital combined temperature and humidity sensor	
Measuring range	0~2000ppm(default) 0~5000ppm (selectable in the order)	1~30ppm	0~50°C (default) -20~60°C selectable	0~100%RH
Display Resolution	1ppm	0.1ppm	0.1°C	0.1%RH
Accuracy@25°C(77°F)	±30ppm + 3% of reading	±10%	±0.5°C	±3%RH
Life time	15 years (normal)	5~7 years	10 years	
Calibration cycle	ABC Logic Self Calibration	—	—	—
Response Time	<2 minutes for 90% change	<1 minute (for 10ppm hydrogen, 30ppm ethanol) <5 minute (for a cigarette) in 20m ² room	<10 seconds to reach 63%	
Warm up time	72 hours (first time) 1 hour (operation)			
Electrical Characteristics				
Power supply	24VAC/VDC			
Consumption	3.5 W max. ; 2.5 W avg.			
Outputs	Up to three analog outputs 0~10VDC (default) or 4~20mA (selectable by jumpers) 0~ 5VDC (selected in placing order, cannot be changed)			
Modbus interface	RS-485 with Modbus protocol, 19200bps rate, 15KV antistatic protection, independent base address.			

Display and Alarm	
LCD Display	White backlit LCD display: CO2+VOC+Temperature&Humidity measurement
Conditions of Using and Installation	
Operation conditions	-20~60°C (-4~140°F); 0~95%RH, non condensing
Storage conditions	0~50°C (32~122°F)/ 20~60%RH
Weight	240g
Dimensions	130mm(L)×85mm(W)×36.5mm(H)
Installation	Wall mount (65mm×65mm or 85mm×85mm or 2"×4" wire box)
Housing IP class	PC/ABS, protection class: IP30
Standard	CE-Approval

■ Models Selection

G01-IAQ-B X Y C -Z 0 1 - U 02/05 - Tab

X: LCD or no LCD

1- basis type without LCD

3- standard type with LCD (LCD displays real-time measurement of CO2+air quality+Temp.+RH)

Y: Power socket

0- without a power socket

3- with a power socket to connect a power adaptor

C: 24VAC/VDC power supply

Z: analog output

3-3xanalog outputs for CO2+air quality +Temp.(default)/RH (selectable by jumpers)

2-2xanalog outputs for CO2+air quality

0-no analog output

U: default analog output type

A- 4~20mA

V- 0~10VDC (default)

V05- 0~5VDC

02/05: CO2 range

02- 0~2000ppm

05- 0~5000ppm

Tab: temperature scaling

T05- 0~50°C (default)

T06- 0~60°C

T26- -20°C~60°C

Accessory (selectable at placing the order)

921: back plate for wall mounting

921+922: desktop bracket

■ Mounting and Dimensions

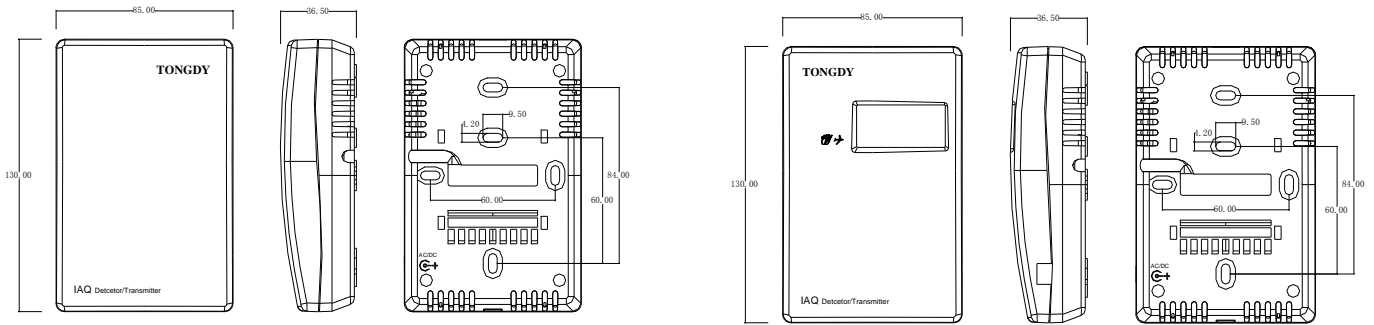

■ Wiring Diagrams

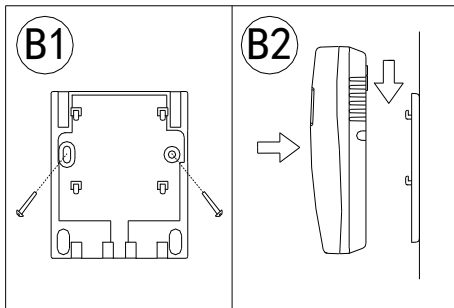
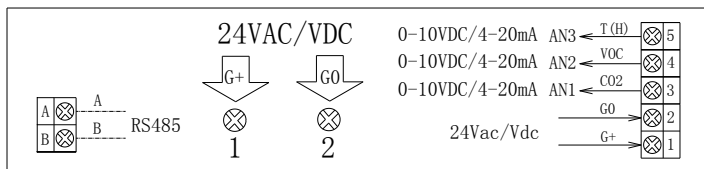

921-Wall mounting plate

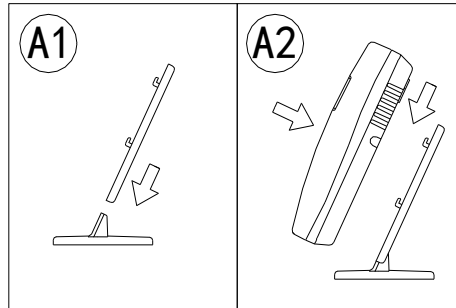

921+922-Desktop bracket